



MEMBER
ABYC[®]
Setting Standards for Safer Boating

Models 217, 230, 230-24 Electronic Bilge Pump Switch



Instead of an unreliable and short-lived mechanical float switch, why not use the original Electronic Bilge Pump Switch? The Water Witch 217, 230 or 230-24 is a submersible electronic bilge pump switch which allows boat owners to forever rid themselves of the archaic outdated float switch. They have no moving parts, requires no adjustments and works in an oily bilge. This eliminates the chance of your battery dying or your pump burning out because of a failed mechanical switch. Water need only touch the lower sensor for 6-8 seconds to activate the switch. The delay eliminates pump stutter and once water has left the sensor, the switch continues to run the pump an additional 14 seconds to clear the output hose. Temperature, humidity or electrical noise will not affect this switch, nor will the 230 interfere with other electronics. This switch comes with an unprecedented 7 year limited warranty and is in use by both the Canadian and U.S. Coast Guards. If it's good enough for them,.....why not for you?

FEATURES & BENEFITS

- *No moving parts & no electrolysis*
- *Impermeable to all bilge substances*
- *Activates when water touches lower sensor*
- *Will not interfere with other electronics*
- *Will not pump a bilge full of gas, diesel or oil*
- *Easy to install and mounts at any angle*
- *30" lead of 16 gauge tinned copper wire*
- *7 year unbeatable limited warranty*
- *Exceeds both United States Coast Guard and U.L. Standards*

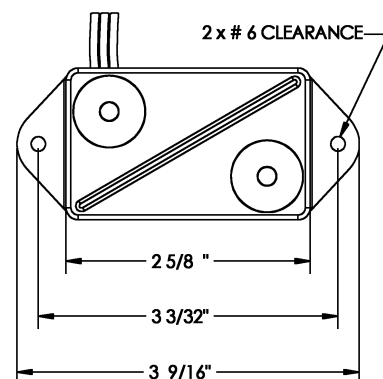

SPECIFICATIONS

Power Required: 12Vdc (model 217, 230)
 24/32Vdc (model 230-24)

Power used: .006 Amps

Size: 2⁵/₈"W x 1⁵/₈"H x 1⁵/₈"D

Weight: 4 ounces

Delay on: 6-8 seconds

Delay off: 15 seconds

Capacity: 217 10 amps @ 12 Vdc
 230 20 amps @ 12 Vdc
 230-24 15 amps @ 24 Vdc

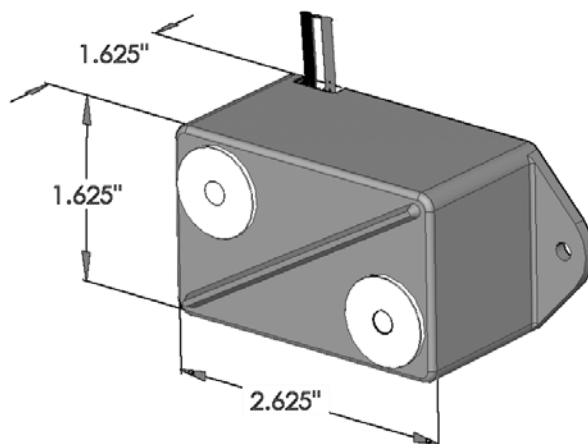

Water Witch, Inc.
 1-800-654-4783

10744 Rockvill Street, Suite 103
 e-mail: info@WaterWitchInc.com

Santee, California 92071
www.WaterWitchInc.com

A fuse and manual override switch are recommended with the installation of a Water Witch electronic bilge switch.

Installation Instructions

1. Disconnect the battery.
 2. Select a mounting location for the Water Witch; the water sensor, the lower sensor furthest from the wires, should be above the standing water level.
 3. Always keep the wire connections above the highest water line.
 4. Connect the wires in the following order following the wiring diagram below
 5. From the Water Witch connect the Tan to the Positive (+) side of the pump or device being controlled, connect the Black to the Ground or the Negative (-) side of the battery and connect the Red to the Positive (+) side of the battery through a fuse.
 6. Reconnect the battery and the pump will run several seconds while the switch self-calibrates.
 7. WHENEVER POWER IS APPLIED, THE SWITCH RUNS THE PUMP FOR SEVERAL SECONDS TO SELF-CALIBRATE.
 8. To test, apply a wet rag across the two sensors on the front of the unit.
- The installation is complete.



Model 217



Model 230

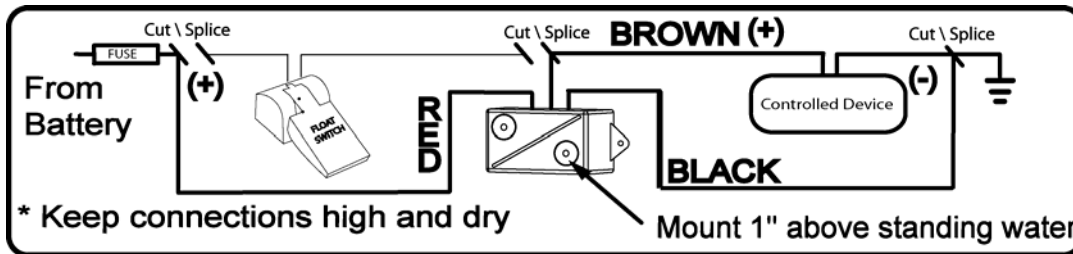

Maintenance

The Water Witch requires little maintenance other than periodic cleaning of the sensors. Ordinarily this consists of hosing it down with fresh water and wiping it off with a clean rag or towel. Some high foaming detergents or high concentration of fish “slime” can delay or prolong cycle times and require more frequent cleaning of the sensors. Periodically check electrical connections for corrosion.



Model 230-24

NOTE:

If large amounts of rain water can enter the bilge, it may dilute the normal, fresh or salt, water outside our sensitivity window. Corrective action can be to switch pump on manually to remove diluted water or to add minerals such as salt, baking soda, bilge cleaners, etc... NORMAL FRESH WATER HAS AMPLE MINERAL CONTENT FOR PROPER OPERATION.

PURCHASE INFORMATION

Model #	Voltage	Max. Load	Category	Warranty
217	12Vdc	10A	electronic bilge pump switch	7 years
230	12Vdc	20A	electronic bilge pump switch	7 years
230-24	24Vdc	15A	electronic bilge pump switch	7 years

Water Witch, Inc.
1-800-654-4783

10744 Rockvill Street, Suite 103
e-mail: info@WaterWitchInc.com

Santee, California 92071
www.WaterWitchInc.com